

Airborne Telemetry

MSC1000-021 Pressure/Thermocouple Scanner Module Airborne Data Acquisition Products

FEATURES

- Provides the interface to thermocouple multiplexers such as the Hades NUX711 series
- Provides the interface to pressure scanners such as the Pressure Systems ESP-48
- 6 excitation outputs (+28V, +15V, +12V, +5V, and -12V)
- 11 programmable gains (1 to 1024)
- Programmable offset in 2.44 mV steps from -5V to +5V
- ZCAL, NCAL, and VCAL.
- Programmable manual balance option



communications
Telemetry & RF Products

Excellence You Can Measure

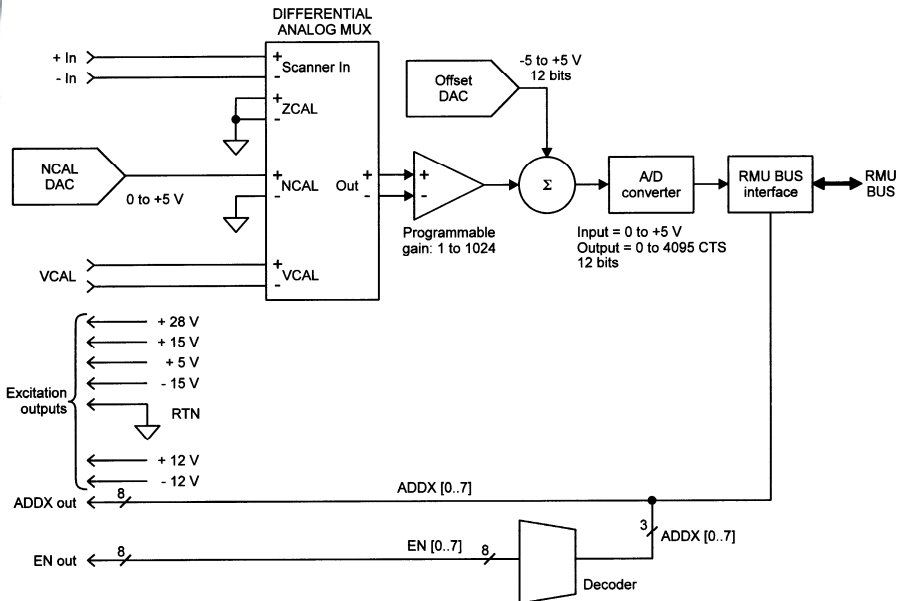

DESCRIPTION

The MSC1000-021 is a fully programmable signal conditioning module for use with external thermocouple multiplexers or pressure scanners. The module provides enable lines, address lines, power lines, excitation, and a differential analog input port.

ELECTRICAL SPECIFICATIONS

Excitation (Per Module)

- 5 Voltage sources: +28 VDC, +15 VDC, +12 VDC, +5VDC, and -12 VDC.
- Accuracy: +4%
- Load regulation: $\pm 3\%$ from no load to full load
- Stability: $\pm 1\%$ over temperature
- Total RMU current limit between 1.0 A and 1.3 A for all positive voltages (per chassis)
- Total RMU current limit between 250 mA and 300 mA for all negative voltages (per chassis)

Input Characteristics (Per Channel)

- Input signal range 5 VPP maximum (differential)
- Input impedance: 1 Megohm minimum
- ACCMR at a gain of 1 is 70 db minimum at 400 Hz with a 1 Kohm unbalance
- Overvoltage protection of $\pm 32V$

Gains (Per Channel)

- Program selectable gains of 1, 2, 4, 8, 16, 32, 64
- Gain accuracy: $\pm 0.5\%$ of selected value
- Temperature stability: $\pm 0.25\%$
- Linearity: ± 0.1 BSL

Channel Offset

- Program selectable in 2.44 mV steps from -5VDC to +5VDC referenced to output. Offset is defined such that a 0 volt offset with a grounded channel input will produce 0 volts at the channel output.

Cal Types

- NCAL: NCAL DAC connected to channel input 0 to 5 Volts, 1.22 mV increments. Accuracy is ± 1 mV, referenced input. Temperature stability is ± 1 mV, referenced to input.
- VCAL: Channel inputs are connected to system VCAL.
- ZCAL: Channel inputs are connected to signal ground.

Balance (Per Channel)

- Algorithm type: amplifier offset
- Balance Algorithm accuracy: $\pm 0.5\%$ full scale

Sample and Hold (Per Channel)

- To occur "on word" only

Output (Per Channel)

- A 5 volt full scale analog signal at a gain of one (1), converted to a 12 bit digital word (1.22 mV/bit)

Miscellaneous

- Channel noise will not exceed $\pm 0.2\%$ full scale at a gain of 1 and $\pm 1\%$ at a gain of 1024.
- Eight (8) addressing lines plus eight (8) enable lines.
- The address lines and the enable lines are controlled by the channel number assigned to a channel. For example, Channel 1 Activates Enable 0 and an address of 0. As soon as Channel "N" is sampled, the address for Channel "N+1" is output. This provides settling time equal to the time between samples.
- An option allows the address and enable lines to be either TTL levels or CMOS levels.

www.L-3Com.com/te



L-3 Communications Telemetry-East
1515 Grundy's Lane
Bristol, PA 19007
Tel: 267-545-7000
Fax: 267-545-0100



L-3 Communications Telemetry-West
9020 Balboa Avenue
San Diego, CA 92123-3507
Tel: 858-694-7500, 800-351-8483
Fax: 858-279-0693